

# BSL722 COLD

## Installation Instructions

EMERGENCY LED DRIVER

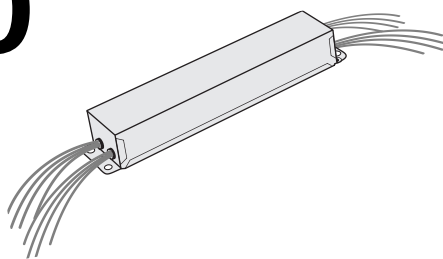

PHILIPS  
**bodine**



### **! IMPORTANT SAFEGUARDS !**

**WHEN USING ELECTRICAL EQUIPMENT, BASIC SAFETY PRECAUTIONS SHOULD ALWAYS BE FOLLOWED, INCLUDING THE FOLLOWING:**

## **READ AND FOLLOW ALL SAFETY INSTRUCTIONS**

1. To prevent high voltage from being present on yellow & yellow/black output leads prior to installation, converter connector must be open. Do not join converter connector to the fuseholder until installation is complete and AC power is supplied to the emergency driver.
2. This product is for use with an LED lighting load and supplies up to 23.1 W of power at a rated current of 700 mA with a voltage between 28.0 VDC and 33.0 VDC in emergency mode for a minimum of 90 minutes.
3. Make sure all connections are in accordance with the National Electrical Code, Canadian Electrical Code and any local regulations.
4. To reduce the risk of electric shock, disconnect both normal and emergency power supplies and converter connector of the emergency driver before servicing.
5. This emergency driver is for factory installation only.
6. This product is suitable for damp locations where the ambient driver temperature is -20°C minimum, +60°C maximum. Product is not suitable for heated air outlets and wet or hazardous locations.
7. An unswitched AC power source is required (120 through 277 VAC, 50 or 60 Hz).
8. Do not install near gas or electric heaters.
9. The use of accessory equipment not recommended by the manufacturer may cause an unsafe condition.
10. Do not use this product for other than intended use.
11. Servicing should be performed by qualified service personnel.
12. This device complies with part 15 of the FCC Rules. Operation is subject to the following two conditions:(1) this device may not cause harmful interference, and (2) this device must accept any interference that may cause undesired operation.
13. This product must be grounded. See the wiring diagrams for details.

### **SAVE THESE INSTRUCTIONS**



Ni - Cd

**THIS PRODUCT INCLUDES RECHARGEABLE NICKEL-CADMIUM BATTERIES.  
THE BATTERIES MUST BE RECYCLED OR DISPOSED OF PROPERLY.**

04/16/18

© Philips Emergency Lighting

# INSTALLATION



**WARNING: TO PREVENT HIGH VOLTAGE FROM BEING PRESENT ON YELLOW & YELLOW/BLACK OUTPUT LEADS PRIOR TO INSTALLATION, CONVERTER CONNECTOR MUST BE OPEN. DO NOT JOIN CONVERTER CONNECTOR TO THE FUSEHOLDER UNTIL INSTALLATION IS COMPLETE AND AC POWER IS SUPPLIED TO THE EMERGENCY DRIVER.**

NOTE: Make sure the necessary branch circuit wiring is available. An unswitched source of power is required. The emergency driver must be fed from the same branch circuit as the AC driver.

## STEP #1 INSTALLING THE EMERGENCY DRIVER

- > Disconnect AC power from the fixture.
- > Refer to Illustration 1 below to install the emergency driver and batteries. Make electrical connections in accordance with the National Electrical Code and any local regulations. Note: This is only an example of one possible installation.

**ILLUSTRATION 1**  
Typical Fixture Assembly

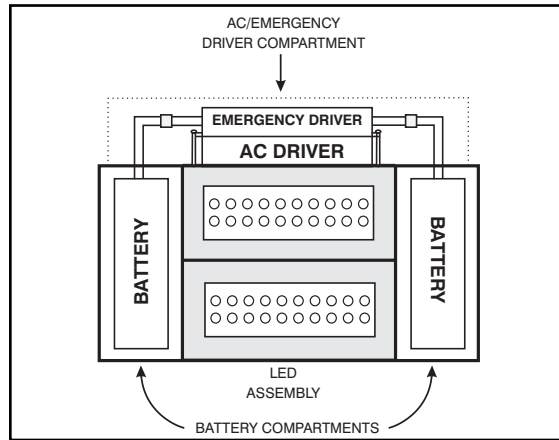

## STEP #2 INSTALLING A TEST SWITCH

- > Refer to Illustration 2 to install a typical low voltage illuminated test switch. Illustration 3 depicts the wiring schematic of a TEST SWITCH and CHARGING INDICATOR LIGHT to the EMERGENCY DRIVER.

**ILLUSTRATION 2**  
Typical (Non-Specific) Illuminated Test Switch

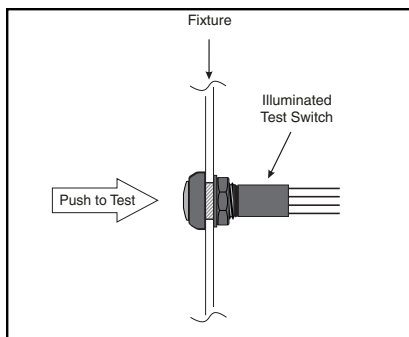

**ILLUSTRATION 3**  
Wiring Schematic

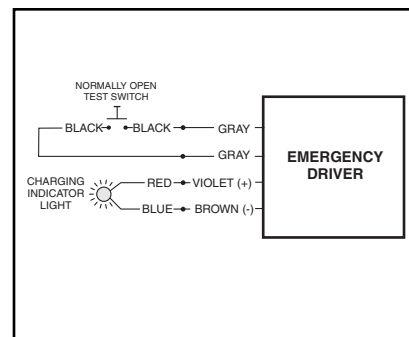



**CAUTION: DO NOT CONNECT THE YELLOW AND YELLOW/BLACK LEADS TOGETHER. THIS MAY DAMAGE THE EMERGENCY DRIVER.**

### STEP #3 ► WIRING THE EMERGENCY DRIVER

- > Connect the yellow emergency driver wire to the positive input of the emergency LED load. Next, connect the negative output wire of the AC driver and the yellow/black emergency driver wire to the negative lead of the emergency LED load. See wiring diagrams on the next page for unswitched, switched, and emergency-only fixtures. Contact factory for other wiring diagrams if needed.
- > Connect the test switch as shown on the wiring diagrams on the next page.
- > Follow the corresponding wiring diagrams to connect the remaining leads.
- > After installation is complete, supply AC power to the emergency driver and join the converter connector to the fuseholder.

### STEP #4 ► EMERGENCY DRIVER QUICK CHECK AND LABELING

- > For short-term testing of the emergency function, the batteries must be charged for at least one hour. The batteries must be charged for at least 24 hours before conducting a long-term test.
- > In a readily visible location, attach the label "CAUTION: This Unit Has More Than One Power Supply Connection Point. To Reduce The Risk Of Electric Shock, Disconnect Both The Branch Circuit-Breakers Or Fuses And Emergency Power Supplies Before Servicing."

## OPERATION

---

When AC power is applied, the charging indicator light is illuminated, indicating the batteries are being charged. When power fails, the emergency driver automatically switches to emergency power, operating the emergency LED load at reduced illumination. When AC power is restored, the emergency driver returns to the charging mode. This emergency driver will operate an LED lighting load at a rated current of 700 mA with a voltage between 28.0 VDC and 33.0 VDC and up to 23.1 W of output power for a minimum of 90 minutes.

## MAINTENANCE

---

Although no routine maintenance is required to keep the emergency driver functional, it should be checked periodically to ensure that it is working. The following schedule is recommended:

1. Visually inspect the charging indicator light monthly. It should be illuminated.
2. Test the emergency operation of the fixture at 30-day intervals for a minimum of 30 seconds. The LED lighting load should operate at reduced illumination.
3. Conduct a 90-minute discharge test once a year. The emergency LED load should operate at reduced illumination for a minimum of 90 minutes.
4. The fuse provided is only for use in the output supply circuit of the emergency driver. If the LED lighting load fails to operate in the emergency mode, inspect the fuse and replace if necessary.



**CAUTION:** To replace fuse, disconnect fuseholder from converter connector and both switched and unswitched AC power from the fixture. Remove the old fuse from the fuseholder and replace with a new 2A, 32 VDC rated, non-time delay blade fuse. Supply AC power to fixture and reconnect converter connector to the fuseholder. Charging indicator light should be illuminated. Contact manufacturer for fuse replacement.

**! REFER ANY SERVICING INDICATED BY THESE CHECKS TO QUALIFIED PERSONNEL !**

# EMERGENCY DRIVER AND AC DRIVER MUST BE FED FROM THE SAME BRANCH CIRCUIT

TYPICAL SCHEMATICS ONLY. MAY BE USED WITH OTHER DRIVERS. CONSULT THE FACTORY FOR OTHER WIRING DIAGRAMS.

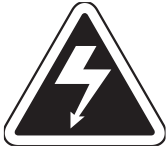

**CAUTION: DO NOT CONNECT THE YELLOW AND YELLOW/BLACK LEADS TOGETHER. THIS MAY DAMAGE THE EMERGENCY DRIVER.**

## WIRING DIAGRAM FOR UNSWITCHED FIXTURE

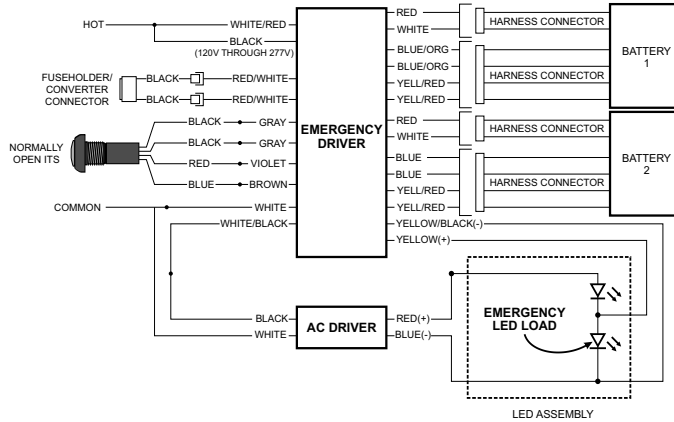

## WIRING DIAGRAM FOR SWITCHED FIXTURE

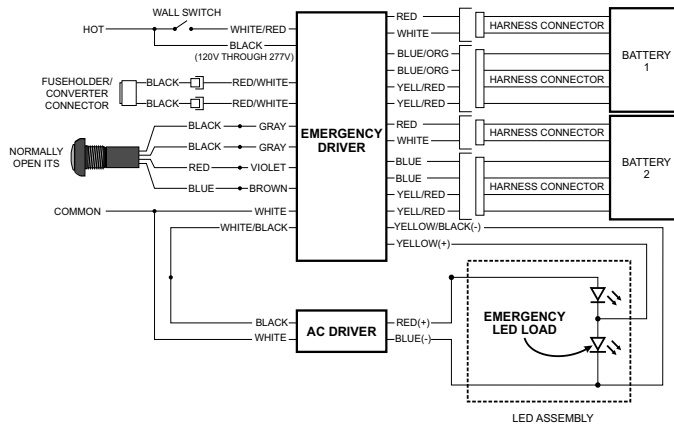

## WIRING DIAGRAM FOR EMERGENCY-ONLY FIXTURE

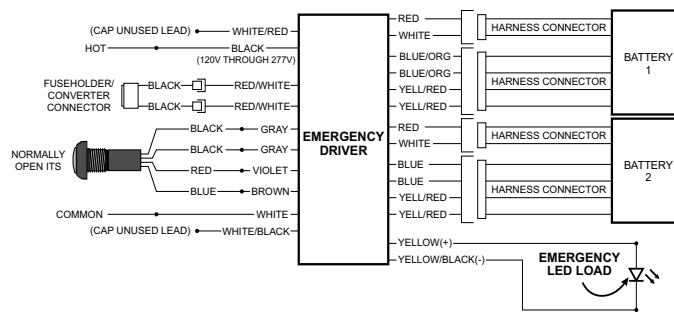

**GROUNDING:** This product must be grounded. Connect the green wire to fixture ground.