

PHILIPS bodine

Emergency Ballasts

Linear Fluorescent

B100



Convenient Code-Compliance
Dry or Damp Locations
End-of-Lamp-Life Compatible

Product order number: B100 (metal case)

Project: _____
Type: _____
Model No: _____ Qty: _____
Date: _____
Notes: _____

Specifications

UL LISTED (UL924 Emergency Lighting Equipment)

Factory or Field Installation
(Dry or Damp)

Illumination Time
90 Minutes (Standard)

Initial Light Output
350 - 450 Lumens

Full Warranty
1 Year (NOT pro-rata)

Dual Input Voltage
120/277 VAC, 60 Hz

AC Input Current
280 mA

AC Input Power Rating
2.5 Watts

Test Switch
Single Pole

Battery
High-Temperature, Maintenance-Free
Nickel-Cadmium Battery
7- to 10-Year Life Expectancy

Battery Charging Current
280 mA

Recharge Time
24 Hours

Charging Indicator Light
LED

Ballast Temperature Rating (Ambient)
0°C to +50°C (32°F to 122°F)
(Damp Location)

0°C to +55°C (32°F to 131°F)
(Dry Location)

Dimensions
9.4" x 2.4" x 1.5" (238 mm x 60 mm x 38 mm)
Mounting Center 8.9" (226 mm)

Weight
2.1 lbs. (1.13 kg)

Benefits:

- Dry or Damp Locations
- Emergency mode lumen output up to 450 lumens
- End-of-Lamp-Life Compatible

Dimensions

9.4" x 2.4" x 1.5" (mounting center - 8.9")

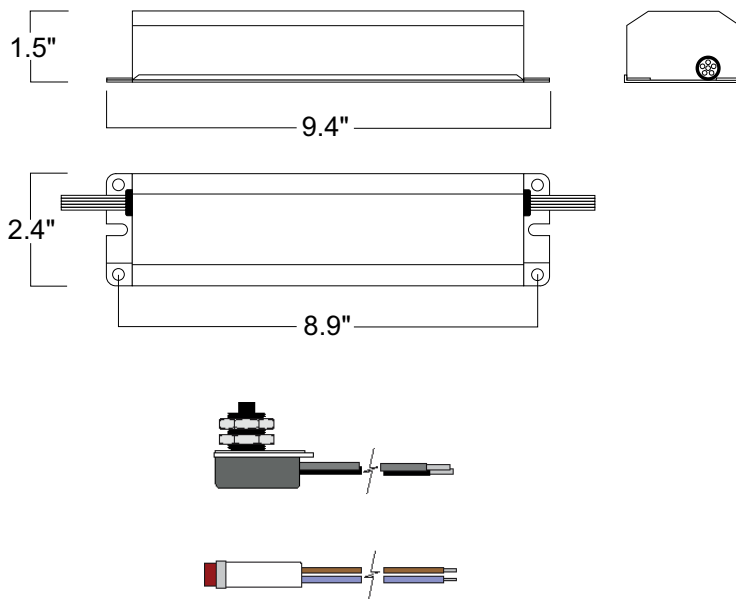

A test switch and charging indicator light is provided.



B100

Flourescent Emergency Ballast, Convenient code-compliance

APPLICATION

The B100 emergency ballast works in conjunction with an AC ballast to convert new or existing fluorescent fixtures into emergency lighting. The emergency ballast consists of a high-temperature nickel-cadmium battery, charger and electronic circuitry. The B100 can be used with most 32 - 40 W (2' - 4') T8, T10, or T12 fluorescent lamps without an integral starter, including U-shaped. It is also compatible with most one-, two-, three- and four-lamp electronic, standard, energy-saving and dimming AC ballasts. If used in an emergency-only fixture, no AC ballast is necessary. The B100 is suitable for indoor and damp locations and for sealed & gasketed fixtures, including fixtures rated for wet locations. It is not suitable for air handling heated air outlets or wet or hazardous locations. For information about specific lamp and ballast compatibility, please call the factory.

OPERATION

When AC power fails, the B100 immediately switches to the emergency mode, operating one lamp at a reduced lumen output for a minimum of 90 minutes. When AC power is restored, the emergency ballast automatically returns to the charging mode and, using a patented circuit, delays AC ballast operation for approximately three seconds to prevent false tripping of the AC ballast end-of-lamp-life shutdown circuits.

INSTALLATION

The B100 does not affect normal fixture operation and may be used with either a switched or unswitched fixture. If a switched fixture is used, an unswitched hot lead must be connected to the emergency ballast. The emergency ballast must be fed from the same branch circuit as the AC ballast. The B100 may be installed inside, on top of or remote from the fixture. The emergency ballast may be remotely installed up to half the distance the AC ballast manufacturer recommends removing the AC ballast from the lamp or up to 50 feet, whichever is less. Installation is not recommended with fixtures where the ambient temperature may fall below 0°C.

EMERGENCY ILLUMINATION

Depending on the wattage and type of lamp selected, the B100 produces 350 to 450 lumens initial emergency light output. During emergency illumination, one lamp is illuminated, even if installed with a multi-lamp AC ballast. Emergency lumen output will be less with a compact fluorescent lamp.

SPECIFICATION

Emergency lighting shall be provided by using a standard fluorescent fixture equipped with a Philips Bodine B100 emergency ballast. This emergency ballast shall consist of a high-temperature, maintenance-free nickel-cadmium battery, charger and electronic

circuitry contained in one 9 3/8" x 2 3/8" x 1 1/2" red metal case. A solid-state charging indicator light to monitor the charger and battery, a single-pole test switch and installation hardware shall be provided. The emergency ballast, using a patented circuit, shall delay AC ballast operation for approximately three seconds to prevent false tripping of AC ballast end-of-lamp-life shutdown circuits. The emergency ballast shall be capable of operating one 32 - 40 W (2' - 4') T8, T10 or T12 fluorescent lamp at reduced illumination in the emergency mode for a minimum of 90 minutes. It shall be suitable for indoor and damp locations and for sealed & gasketed fixtures, including fixtures rated for wet locations. The B100 shall produce 350 to 450 lumens initial emergency light output, have 3.5 Watts of input power and a 9.6 Watt-hour battery capacity and comply with emergency standards set forth by the current NEC. The emergency ballast shall be UL Listed for installation inside, on top of or remote from the fixture and shall be warranted for a full year from date of purchase.

WARRANTY

Model B100 is warranted for one (1) full year from date of purchase. Please see detailed warranty information on our web site.

